

# KOMATSU®

## **XT430-5, XT445L-5,**

## **XT465L-5**

*Tier 4 Final Engine*

### **FELLER BUNCHER**



Photos may include optional equipment.

#### **PEAK HORSEPOWER**

310 HP @ 1700 rpm  
231 kW @ 1700 rpm

#### **OPERATING WEIGHT**

XT430	XT445L	XT465L
66,359 lb	72,091 lb	74,516 lb
30,100 kg	32,700 kg	33,800 kg

XT430 XT445L XT465L

# WALK-AROUND

XT430 XT445L XT465L



Photos may include optional equipment.

## PEAK HORSEPOWER

310 HP @ 1700 rpm  
231 kW @ 1700 rpm

## OPERATING WEIGHT

XT430	XT445L	XT465L
66,359 lb	72,091 lb	74,516 lb
30,100 kg	32,700 kg	33,800 kg

**The New Komatsu XT-5 Series Track Feller Bunchers - This Changes Everything!**

The new Komatsu XT-5 Series sets high industry standards of excellence for Track Feller Bunchers and features:

- Gull-wing engine hood service access
- Increased lift capacity
- Cab relocated to the left side
- New rugged undercarriages
- KOMTRAX® telematics system
- Powerful, fuel-efficient engine

Read on to learn more about this new Komatsu XT-5 Series, and why This Changes Everything!

**Gull-wing engine hood folds down providing an elevated service work platform.**

- Robust gull-wing design provides a secure footing area with a 500 lbs. (227 kg) load capacity.
- Offers excellent visibility and service access to all engine-related components; including most filters

**Four (4) rugged swing-out service doors open wide** to provide excellent service access to key components.



Service work platform

**Greater lift capacity at full reach** provides increased productivity; (75% on XT430-5/XT445L-5 and 16% on XT465L-5)

**Relocated Cab has superior visibility to both sets of tracks** through the side door and boom side windows.

**A powerful new Cummins QSL9 engine provides a peak output of 310 HP (231 kW) @ 1700 rpm** and is EPA Tier 4 final emissions certified. Improved performance vs. previous XT-3 models includes:

- 7% more displacement: 8.9 liters vs. 8.3 liters
- 7% higher peak torque: 1,070 lb-ft (1,451 Nm) vs 1,000 lb-ft (1,356 Nm) @ 1,400 rpm
- 3% more peak HP: 310 (1700 rpm) vs 300 (2000 rpm)
- **Fuel consumption drops by up to 10%!**  
*(results based on actual measured values using the XT445L-5 prototype vs. the XT445L-3 model - each operator's results may vary)*

**Lower Fuel Consumption achieved through:**

- Auto-idle down engine monitoring control.
- Independent, temperature-based variable speed engine radiator and hydraulic oil cooler fans.
- A separate attachment pump for the grapple, accumulator, wrist and disc saw improves performance and efficiency.
- HST motor has an auto-shift feature that provides for high-torque, low-speed travel starts.
- Integrated Tier 4 Final engine installation utilizing DOC and SCR technology with no DPF required.

New

**Komatsu's KOMTRAX® telematics system is standard:**

- Using satellite-based technology, KOMTRAX transmits valuable information such as location, utilization and maintenance records to a PC via an internet website.
- Custom machine reports are available for identifying machine operating trends.
- KOMTRAX provides advanced machine troubleshooting capabilities by monitoring machine health.
- No subscription-fee is required throughout the life of the machine.

New

New

**New Komatsu rugged undercarriages provide significantly longer service life** due to the following key improvements:

- Rugged 8.5" track chain links are stronger at resisting "twist".
- Track rollers and idler bushings are made of high-density material allowing longer wear.
- XT445L-5 / XT465L-5 removeable track guards have larger roller side openings to reduce mud packing and facilitate cleaning.
- Final drives have a new triple labyrinth floating seal housing to protect the seal against mud packing.
- XT445L-5 / XT465L-5 track sliders have a reduced angle producing 30% lower contact pressure for reduced wear.
- Choice of standard track sliders or optional carrier rollers.

New

New

New

New

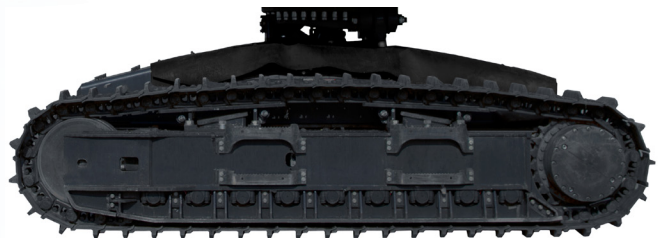

**Closed loop track drive with dedicated pumps allows simultaneous multi-functioning of travel, swing, boom and tool** without compromising power between work and travel functions.

**Heavy-duty 4-way leveling system** (XT445L-5 /XT465L-5) provides simultaneous front/rear/side leveling to maximize slope productivity:

**Exceptional maneuverability in tight areas:**

- Proven set-back boom design allows the operator to cut close to the tracks for improved productivity.
- Short-tail swing and closed-loop independent track drive make it easy to operate in dense forest conditions.

**New hydraulic pump system provides faster cycle times:**

- 17% larger capacity piston pumps and electronically-controlled hydraulic flow provide quick response time.
- Separate pumps for implement, attachment and disc saw operate independently to provide flow only when needed.

New

# WALK-AROUND

## HIGH PERFORMANCE & PRODUCTIVITY

**Powerful swing torque and high tractive effort** deliver fast and dependable performance in demanding sloped and rough terrain conditions.

### Cold weather operation is facilitated with:

- Standard charge oil relief heater provides for fast hydraulic oil warm-up.
- Optional fuel-fired jacket water and hydraulic oil pre-heater facilitates faster cold weather start-ups.

## SUPERIOR OPERATOR COMFORT & CONVENIENCE

**State-of-the-art operator cab includes many standard features:**

- Large front, side and skylight polycarbonate windows provide a commanding "widescreen" view of the working area:
  - Front and skylight windows are 1.25" (32 mm) thick; side windows are 0.5" (13 mm) thick.
  - Eleven (11) LED lights provide excellent illumination.
- Standard rear view monitoring system with one camera provides excellent rear area visibility. An optional side view camera system adds a second camera to provide visibility along the right side of the machine. **New**
- Komatsu was "1st-in-the-forest" to offer the state-of-the-art IQAN-MD4 digital control system on track forest machines. This IQAN technology leadership position continues with additional operator functionality:
  - Highly intuitive Komatsu programming along with a rugged large 7" (18 cm) LED color touchscreen makes operation and system navigation easy.
  - New functionality allows up to 3 different operators to program their individual control patterns for increased multi-operator productivity. Each operator can easily make and save their own desired control changes, including performing a reset back to the original factory settings, if necessary. **New**
- All switches and controls are conveniently located within easy reach of the operator. An "infinitely variable" travel speed control allows the operator to fine-tune travel speed for improved comfort. Operator sets the desired maximum speed while maintaining the full range of pedal travel movement - no longer requires having to meter pedal travel to maintain a certain speed. **New**
- High capacity automatic air conditioner, heater and defroster system ensures all-season operating comfort.
- A long list of other operator comfort amenities is standard including: AM/FM/Weather band stereo radio with iPod/MP3 input jack, 2 x 12-volt power outlets, cellphone holder, cupholder, coat hook, and insulated drink bottle and lunch box cooler.
- Aftertreatment components are designed in conjunction with the engine for efficiency and long life. The SCR system passively performs catalytic reduction, with no action required from the operator and no interference with machine operation under normal duty cycles. **New**
- Automatic liquid chemical fire suppression system and readily accessible handheld fire extinguisher are standard. **New**

## RUGGED RELIABILITY & DURABILITY

**Robust forestry-specific guarding system covers the boom/arm/rear hydraulic tubes and hoses** to provide superior protection and shed debris. **New**

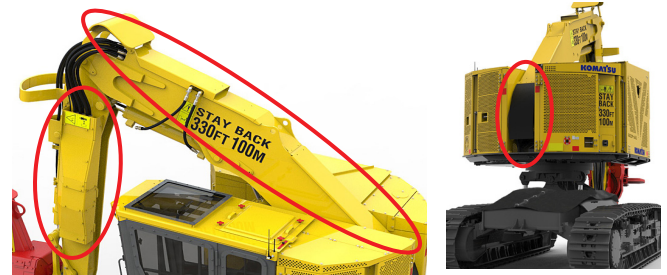

**Larger capacity hydraulic piston pumps for Implement, Attachment and Disc Saw:** **New**

- Operate at 500 rpm lower speed for increased durability while delivering high performance flow.
- Each pump has a pre-charged (pressurized) suction inlet to reduce cavitation risk.

**Steel tubes are utilized for all hydraulic delivery and return lines** to increase reliability and durability. **New**

**High capacity cooling system features a large radiator, charge air cooler and hydraulic oil cooler.** Separate temperature-based, variable speed engine and hydraulic oil cooler fans are equipped with an auto-reversing function to help purge debris and maintain cooling efficiencies. **New**

**Reduced PTO gearbox ratio lowers PTO speed** to decrease friction/wear and extend service life. **New**

**Optional pump drive oil cooler** provides additional cooling to extend pump drive gear box life.

## EASE OF MAINTENANCE

**Sloped operator cab and engine/pump compartment roofs shed debris.** **New**

**Engine and hydraulic coolers are located in the rear to reduce debris build-up and provide easier access.** Auto-reversing fans help purge debris and maintain cooling efficiencies. **New**

**Innovative hydraulic tank system requires 55% less hydraulic oil (refill = 57 gal (216 liters))** **New**

- Self-pressurized 2-tank design: Tank #1 operates at 5 psi pressure (for the piston pumps) and tank #2 operates at no pressure (for the gear pumps and case return).
- Unique "Hydro-Nucleation" filtration technology removes trapped air bubbles from the hydraulic oil in the pressurized tank to reduce the risk of piston pump cavitation.
- Electric hydraulic tank oil fill pump facilitates refilling.
- Hydraulic tank vacuum pump helps to reduce oil spills and keep the machine clean when servicing the hydraulic system.

**New work equipment hydraulic system design relocates the attachment valve to the arm for ease of service.** **New**

XT430 XT445L XT465L

# SPECIFICATIONS



## ENGINE

Model	Cummins QSL9 diesel engine
Type	Water-cooled, 4-cycle, direct injection
Aspiration	VGT™ Turbocharger, infinitely adjustable with electronic controls. High pressure fuel injection, in cylinder advanced combustion technology, cooled EGR.
Number of cylinders	In-line, 6-cylinder
Bore	114 mm <b>4.49"</b>
Stroke	135 mm <b>5.69"</b>
Piston displacement	9 ltr <b>543 in<sup>3</sup></b>
Horsepower:	
Peak	231 kW <b>310 HP @ 1700 rpm</b>
Rated	226 kW <b>303 HP @ 1800 working rpm</b>
Peak Torque	1451 Nm <b>1070 lb-ft @ 1400 rpm</b>
Fan Drive Type	Hydraulic

\*Complies with U.S. EPA Tier 4 Final emissions standard



## ELECTRICAL SYSTEM

Type	24V with master disconnect
Alternator	24V, 100A
Work Lights	11 - LED



## HYDRAULIC

Implement pump	Variable displacement piston, Max Flow - 324 liter/min <b>86 GPM</b>
Attachment pump	Variable displacement piston, Max Flow - 200 liter/min <b>53 GPM</b>
Saw pump	Variable displacement piston, Max Flow - 143 liter/min <b>38 GPM</b>
Track drive pump	2x Variable displacement piston, Max Flow - 167 liter/min <b>44 GPM</b>
Fan pump	2x Gear, Max Flow - 44 liter/min <b>11 GPM</b>
Charge pump	2x Gear, Max Flow - 95 liter/min <b>25 GPM</b>
Travel motor	Variable displacement piston
Swing motor	Fixed displacement bent axis piston
Cooling	Independent Radiator/CAC/ Hydraulic oil coolers with thermostatically controlled fans



## DRIVES AND BRAKES

	XT430-5	XT445L-5	XT465L-5
Drive Method	Hydrostatic, independent closed loop	Hydrostatic, independent closed loop	Hydrostatic, independent closed loop
Steering control	Foot Pedals	Foot Pedals	Foot Pedals
Max travel speed			
High	4.6 km/h <b>2.9 mph</b>	4.6 km/h <b>2.9 mph</b>	4.6 km/h <b>2.9 mph</b>
Low	2.6 km/h <b>1.6 mph</b>	2.1 km/h <b>1.3 mph</b>	2.1 km/h <b>1.3 mph</b>
Max tractive effort	29,450 kgf <b>64,926 lbf</b>	34,382 kgf <b>75,799 lbf</b>	34,382 kgf <b>75,799 lbf</b>
Service brake	Hydraulic	Hydraulic	Hydraulic
Parking brake	Hydraulic	Hydraulic	Hydraulic



## LEVELING SYSTEM

	XT430-5	XT445L-5	XT465L-5
Type	Non-Leveling	2-cylinder, 4-way heavy duty	2-cylinder, 4-way heavy duty
Leveling angle			
Front	--	27° / 51%	25° / 47%
Rear	--	5° / 9%	6° / 11%
Side/Side	--	20° / 36%	18° / 32%

# SPECIFICATIONS



## SWING SYSTEM

	XT430-5	XT445L-5	XT465L-5
Rotation	Continuous rotation	Continuous rotation	Continuous rotation
Bearing	Heavy duty, 22-bolt Single row bearing	Heavy duty, 22-bolt Single row bearing	Heavy duty, 37-bolt Double row bearing
Drive method	Hydrostatic	Hydrostatic	Hydrostatic
Swing speed	0 to 7.0 rpm	0 to 7.0 rpm	0 to 7.0 rpm
Swing torque	79,100 Nm, <b>58,341 lb-ft</b>	79,100 Nm, <b>58,341 lb-ft</b>	79,100 Nm, <b>58,341 lb-ft</b>
Swing brake	Dynamic	Dynamic	Dynamic
Parking brake	Hydraulic	Hydraulic	Hydraulic



## UNDERCARRIAGE

	XT430-5	XT445L-5	XT465L-5
Carbody	HD boxed frame structure with flat bottom and storage trunk	HD boxed frame structure with flat bottom and storage trunk	HD boxed frame structure with flat bottom and storage trunk
Track frame	Box-section, bolted	Box-section, bolted	Box-section, bolted
Track type	Grease sealed	Grease sealed	Grease sealed
Number of shoes/links	47 per side	46 per side	47 per side
Track rollers	9 per side	8 per side	9 per side
Track pitch	216 mm, 8.5"	216 mm, 8.5"	216 mm, 8.5"



## BOOM PERFORMANCE

	XT430-5	XT445L-5	XT465L-5
Reach at 1.5 m 5' height			
Maximum	6,682 mm, <b>21'7"</b>	6,536 mm, <b>21'5"</b>	6,536 mm, <b>21'5"</b>
Minimum	2,328 mm, <b>7'8"</b>	2,328 mm, <b>7'8"</b>	2,328 mm, <b>7'8"</b>
Cutting Swath*	4,354 mm, <b>13' 11"</b>	4,208 mm, <b>13' 9"</b>	4,208 mm, <b>13' 9"</b>
Lifting capacity** @1.5 m 5' pin height (less attachment)			
@ 3.0 m 10'	11,900 kg, <b>26,235 lb</b>	11,900 kg, <b>26,235 lb</b>	14,200 kg, <b>31,398 lb</b>
@ 4.6 m 15'	8,100 kg, <b>17,857 lb</b>	8,000 kg, <b>17,637 lb</b>	9,760 kg, <b>21,519 lb</b>
@ 6.0 m 20'	4,900 kg, <b>10,803 lb</b>	4,800 kg, <b>10,582 lb</b>	5,940 kg, <b>13,098 lb</b>
@ Full Reach	4,500 kg, <b>9,921 lb</b>	4,500 kg, <b>9,921 lb</b>	5,590 kg, <b>12,326 lb</b>

\* Cutting swath (less attachment) - Swing center to attachment pin

\*\* Feller buncher boom and arm, designed for 20-22" high speed disc saws.



## COOLANT & LUBRICANT CAPACITY (REFILLING)

	XT430-5	XT445L-5	XT465L-5
Fuel tank	840 liters, <b>222 U.S. gal</b>	651 liters, <b>172 U.S. gal</b>	526 liters, <b>140 U.S. gal</b>
Cooling system	35.7 liters, <b>9.43 U.S. gal</b>	35.7 liters, <b>9.43 U.S. gal</b>	35.7 liters, <b>9.43 U.S. gal</b>
Engine oil pan	18.9 liters, <b>4.99 U.S. gal</b>	18.9 liters, <b>4.99 U.S. gal</b>	18.9 liters, <b>4.99 U.S. gal</b>
Final drive per side	11 liters, <b>2.91 U.S. gal</b>	11 liters, <b>2.91 U.S. gal</b>	11 liters, <b>2.91 U.S. gal</b>
Swing gear box	4.3 liters, <b>1.14 U.S. gal</b>	4.3 liters, <b>1.14 U.S. gal</b>	4.3 liters, <b>1.14 U.S. gal</b>
Hydraulic tank	216 liters, <b>57 U.S. gal</b>	216 liters, <b>57 U.S. gal</b>	216 liters, <b>57 U.S. gal</b>
DEF	56.8 liters, <b>15 U.S. gal</b>	56.8 liters, <b>15 U.S. gal</b>	56.8 liters, <b>15 U.S. gal</b>
Gear box (PTO)	6.2 liters, <b>1.63 U.S. gal</b>	6.2 liters, <b>1.63 U.S. gal</b>	6.2 liters, <b>1.63 U.S. gal</b>
Hood tilt	4.5 liters, <b>1.19 U.S. gal</b>	4.5 liters, <b>1.19 U.S. gal</b>	4.5 liters, <b>1.19 U.S. gal</b>



## OPERATING WEIGHT (LESS ATTACHMENT)

	XT430-5	XT445L-5	XT465L-5
Track shoes	600 mm, <b>SG 24"</b>	600 mm, <b>SG 24"</b>	600 mm, <b>SG 24"</b>
Operating weight*	30,100 kg, <b>66,359 lb</b>	32,700 kg, <b>72,091 lb</b>	33,800 kg, <b>74,516 lb</b>
Ground pressure	58.5 kPa, <b>8.5 psi</b>	66.8 kPa, <b>9.7 psi</b>	66.8 kPa, <b>9.7 psi</b>

\*Operating weight includes feller buncher boom, feller buncher arm, 1/2 tank of fuel, rated capacity of lubricants, coolant, operator and standard equipment.

XT430 XT445L XT465L



## DIMENSIONS

	XT430-5	XT445L-5	XT465L-5
<b>A</b> Overall length (with attachment**)	10,632 mm <b>34' 11"</b>	10,487 mm <b>34' 5"</b>	10,632 mm <b>34' 11"</b>
<b>B</b> Overall height* (to top of cab)	3,579 mm <b>11' 9"</b>	3,854 mm <b>12' 8"</b>	3,854 mm <b>12' 8"</b>
<b>C</b> Overall track frame width	3,140 mm <b>10' 4"</b>	3,140 mm <b>10' 4"</b>	3,176 mm <b>10' 5"</b>
<b>D</b> Overall track length	4,900 mm <b>16' 1"</b>	4,760 mm <b>15' 7"</b>	4,893 mm <b>16' 1"</b>
<b>E</b> Track length (sprocket center to idler center)	3,877 mm <b>12' 9"</b>	3,666 mm <b>12' 0"</b>	3,800 mm <b>12' 6"</b>
<b>F</b> Length (center circle to extended boom)	6,582 mm <b>21' 7"</b>	6,436 mm <b>21' 1"</b>	6,436 mm <b>21' 1"</b>
<b>G</b> Track gauge	2,540 mm <b>8' 4"</b>	2,540 mm <b>8' 4"</b>	2,576 mm <b>8' 5"</b>
<b>H</b> Tail swing radius	1,848 mm <b>6' 1"</b>	1,848 mm <b>6' 1"</b>	1,848 mm <b>6' 1"</b>
<b>I</b> Ground clearance	722 mm <b>2' 4"</b>	806 mm <b>2' 8"</b>	794 mm <b>2' 7"</b>
<b>J</b> Overall width (upper structure)	3,106 mm <b>10' 2"</b>	3,106 mm <b>10' 2"</b>	3,106 mm <b>10' 2"</b>
<b>K</b> Grouser height	71.4 mm <b>0' 3"</b>	71.4 mm <b>0' 3"</b>	71.4 mm <b>0' 3"</b>

\* : Including grouser height  
 \*\* : Attachment Quadco 22C

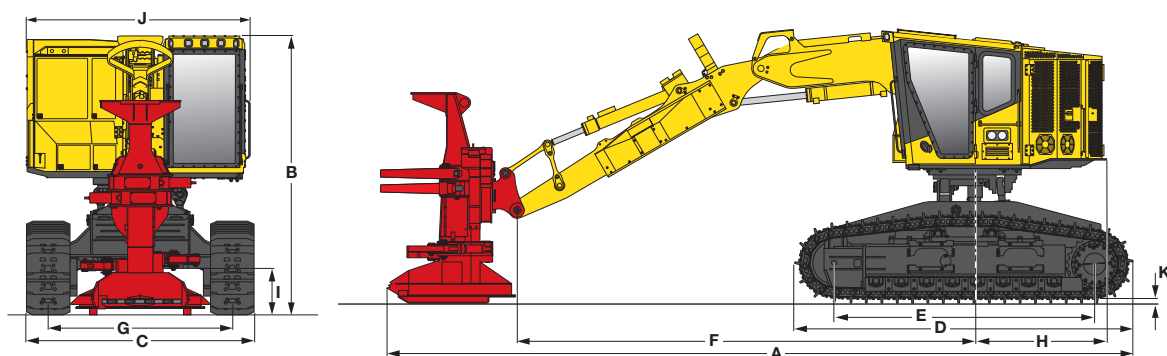

## TRANSPORT DIMENSIONS (W/O ATTACHMENT)

Model	Machine Height (A)	Trailer (B)	Transport Height (C)	Transport Width		Transport Length	
				600 mm, 24"	700 mm, 28"	Dimension (D)	Dimension (E)
<b>XT430-5</b>	3,598 mm, <b>11' 10"</b>	457 mm <b>18"</b>	4,055 mm <b>13' 4"</b>	3,140 mm <b>10' 4"</b>	3,240 mm <b>10' 8"</b>	2,680 mm <b>8' 10"</b>	8,714 mm <b>28' 7"</b>
		559 mm <b>22"</b>	4,157 mm <b>13' 8"</b>				
		610 mm <b>24"</b>	4,208 mm <b>13' 10"</b>				
<b>XT445L-5</b>	3,695 mm, <b>12' 1"</b>	457 mm <b>18"</b>	4,152 mm <b>13' 7"</b>	3,140 mm <b>10' 4"</b>	3,240 mm <b>10' 8"</b>	2,588 mm <b>8' 6"</b>	8,840 mm <b>29' 0"</b>
		559 mm <b>22"</b>	4,254 mm <b>13' 11"</b>				
		610 mm <b>24"</b>	4,305 mm <b>14' 1"</b>				
<b>XT465L-5</b>	3,701 mm, <b>12' 2"</b>	457 mm <b>18"</b>	4,158 mm <b>13' 8"</b>	3,176 mm <b>10' 5"</b>	3,276 mm <b>10' 9"</b>	2,591 mm <b>8' 6"</b>	8,840 mm <b>29' 0"</b>
		559 mm <b>22"</b>	4,260 mm <b>14' 0"</b>				
		610 mm <b>24"</b>	4,311 mm <b>14' 2"</b>				

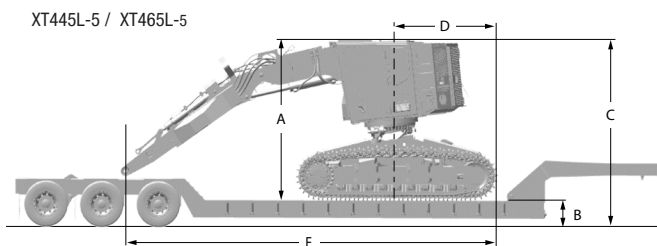
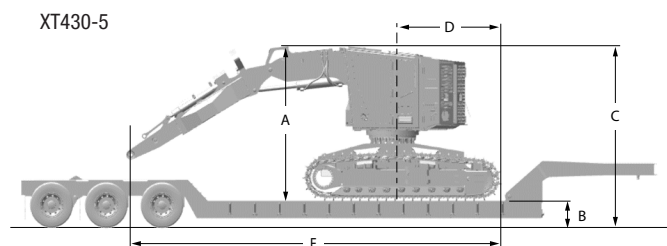



## STANDARD EQUIPMENT

- Alternator, 100 ampere, 24V
- Air cleaner, dry type with air intake pre-cleaner
- Auto-idle shutdown system
- Automatic air conditioner, heater & defroster with pressurization and 6 adjustable vents
- Batteries, 2 x 12V, 950 AH
- Cab, ROPS/OPS/FOPS/TOPS/ FOG/WCB/Oregon OSHA certified forestry:
  - 2 x 12V power outlets
  - Cellphone holder, adjustable
  - Coat hook, magnetic and moveable base
  - Cupholder, fold-down/up
  - Literature box with cover
  - Lockable door
  - Insulated drink bottle & lunch box cooler
  - Ventilation fan
- Carbody, wide gauge with storage trunk
- Continuous swing rotation
- Control handles, Sure Grip
- Cooling:
  - Engine - temperature-sensing auto-reversing fan
  - Hydraulic oil cooler - temperature-sensing auto-reversing fan
  - Charge air cooler - temperature-sensing auto-reversing fan
- Electrical system master disconnect switch
- Electrical joystick/foot pedal controls
- Emergency escapes, 3 (front window, side door and roof hatch)
- Engine, Cummins QSL9, liter, 310 HP (231 kW) Peak @1700 rpm
- Engine compartment service light
- Engine interface monitoring system
- Final drives, Komatsu with spring-applied oil released track brakes
- Fire extinguisher, 10 lb. hand held
- Fire suppression system, automatic liquid chemical
- Fuel water separator
- Heater, charge oil relief
- Horn, electric
- Hydraulic system, load sensing
- Hydraulic tank oil refill pump, 24V
- Hydraulic tank vacuum pump
- Instrument panel with switches, dials, LED warning lights, and engine stop button
- IQAN-MD4 Digital Control System with 7" (18 cm) LED color touch screen display
- KOMTRAX® monitoring system
- Leveling, 4-way HD cab leveling (XT445L-5/XT465L-5)
- Light, Interior dome LED
- Muffler with blanket
- Operator Identification System
- Pumps:
  - Attachment, 1 x VDPP, 53 gpm (200 ltr/min)
  - Implement, 1 x VDPP, 86 gpm (324 ltr/min)
  - Saw drive, 1 x VDPP, 38 gpm (143 ltr/min)
  - Track drive, 2 x VDPP, 44 gpm (167 ltr/min) each
  - Fan, 2 x Gear, 11 gpm (44 ltr/min) each
  - Charge, 1 x Gear, 25 gpm, (95 ltr/min)
- Radio - AM/FM Weather Band stereo with iPod/MP3 input jack
- Rear view monitoring system (1 camera)
- Rubber debris skirt
- Seat, adjustable high back suspension
- Seat belt, 3" retractable
- Swing bearing, HD 22-bolt single row (XT430-5/XT445L-5)
- Swing bearing HD 37-bolt double row (XT465L-5)
- Swing motor, 56cc
- Track adjusters, hydraulic
- Track chain, greased sealed Komatsu 8.5" (216 mm) pitch
- Track drive, closed loop
- Track motors, 2-speed VDPP auto-shift with variable speed control
- Track rollers
- Track shoes, 24" (600 mm) single grouser
- Track sliders
- Travel alarm
- Travel pedals
- Windows, polycarbonate
  - Front & skylight windows, 1.25" (32 mm)
  - Left, right & rear windows, 0.5" (13 mm)
- Work lights, 11 LED type



## OPTIONAL EQUIPMENT

- Arms
  - Feller Buncher, 13'0" (3960 mm) straight with tree deflector
- Booms
  - Feller Buncher 14'10" (4530 mm)
- Carrier rollers
- Heater, fuel-fired jacket water and hydraulic oil pre-heater
- Hydraulic systems
  - Disc saw
  - Bar saw, Intermittent disc saw, Combination disc/bar saw
- Oil cooler, pump drive
- Side view monitoring system (1 camera)
- Track shoes
  - 28" (700 mm) single grouser
  - 28" (700 mm) double grouser (XT430-5)
- Uptime spare parts kits
  - Base machine
  - Engine filters



## ATTACHMENT OPTIONS

- Quadco 20-22" high speed disc saws
- Quadco 24" high speed disc saws (XT465L-5)

# KOMATSU®

*Note: All comparisons and claims of improved performance made herein are made with respect to the prior Komatsu model unless otherwise specifically stated.*

XT430 XT445L XT465L